



Completely tamperproof - ensures continuity of the original system design parameters

SERIES FC FLOW CONTROL VALVES

1/4" - 3"

FEATURES/BENEFITS:

- Maintain constant flow with inlet pressure fluctuation from 15 to 120 PSI (1 Bar to 8 Bars) with $\pm 15\%$ accuracy. Test equipment is NIST certified.
- For corrosive and ultra-pure liquid applications.
- No metals in contact with the liquid.
- Standard flow ranges from 1/4 GPM to 8 GPM; 9 to 120 GPM by special order.
- Automatic in operation – no adjustments.

IMPORTANT:

These flow controls are designed for liquids similar in viscosity to water. All applications should be tested for flow characteristics and chemical compatibility to insure desired results. Swelling of the diaphragms in certain liquids will result in loss of flow rate accuracy. An in-line strainer or filter should be installed before the flow control when suspended solids are present, and for all applications below 1.0 GPM (3.8 LPM).

MATERIALS OF CONSTRUCTION:

The standard Series FC flow controls are constructed of TYPE 1, GRADE 1 PVC (Polyvinyl Chloride) with diaphragms of EPDM. Stainless steel fasteners are non-wetted. Bodies are also available in virgin polypropylene, PTFE and Kynar® PVDF. Consult factory.

APPLICATION:

Recommended whenever flow rate must be maintained regardless of unplanned or fluctuating demand elsewhere: Install Series FC prior to each point of use to eliminate surges and sudden drops in flow.

OPERATION AND INSTALLATION:

The Series FC flow controls are used to maintain a constant predetermined flow in a system. They must be installed in the correct flow direction (indicated by label) to work properly. They utilize a diaphragm which changes shape with inlet pressure changes, thus maintaining a constant flow rate. Standard flow ranges are from 1/4 GPM to 8 GPM with 9 - 120 GPM by special order (.95 LPM to 454 LPM). The minimum pressure drop needed across the flow control is 15 PSI (1 Bar) in order to get the desired flow.

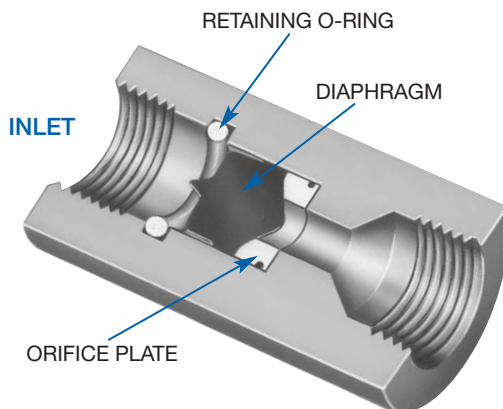

Single diaphragm design at left used for 1/4 GPM through 8 GPM (.95 LPM - 30 LPM) constant flow rates. All higher flow rates use multi-diaphragm design (consult factory for availability).

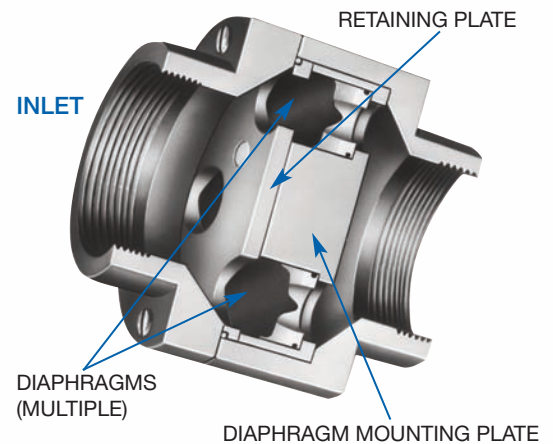

TEMPERATURE AND PRESSURE:

The Series FC flow controls can operate from 40°F - 140°F (5°C - 60°C) with PVC bodies and diaphragms. With optional polypropylene, PTFE or Kynar® PVDF bodies they can operate from 40°F - 180°F (5°C - 82°C) with EPDM diaphragms. The Series FC flow controls must have at least 15 PSI (1 Bar) pressure drop across the control in order to deliver the rated flow. Maximum pressure is 120 PSI (8 Bars). See temperature vs. pressure chart below.

ORDERING INFORMATION:

Order by part number as follows: The basic number is given in the chart below, follow it "EP" for EPDM seals respectively. This is then to be followed by the required flow rate. **For Example:** A 3/8" NPT control with EPDM seals having a 1/2 GPM flow is part number FC037EP-1/2-PV. Specify exact chemicals, pressures, and temperatures. For body materials other than PVC please contact our Sales Department. Standard threads are NPT. For BSP threads be sure to specify on order.

Series FC – Pipe Size			1/4"		3/8"		1/2"		3/4"	
Basic Part Number			FC025		FC037		FC050		FC075*	
Flow Rate Gal/Min.	Flow Rate Litres/Min.	Number of Control Ass'y In Housing	Overall Length in.	Diameter mm	Overall Length in.	Diameter mm	Overall Length in.	Diameter mm	Overall Length in.	Diameter mm
1/4	.95	1	2 3/8 60.3	1 1/8 28.6	2 54.0	1 1/8 28.6	2 1/4 63.5	1 1/4 31.8		
1/2	1.9	1	2 3/8 60.3	1 1/8 28.6	2 54.0	1 1/8 28.6	2 1/4 63.5	1 1/4 31.8		
3/4	2.8	1	2 3/8 60.3	1 1/8 28.6	2 54.0	1 1/8 28.6	2 1/4 63.5	1 1/4 31.8		
1	3.8	1	2 3/8 60.3	1 1/8 28.6	2 54.0	1 1/8 28.6	2 1/4 63.5	1 1/4 31.8		
1 1/2	5.7	1	2 3/8 60.3	1 1/8 28.6	2 54.0	1 1/8 28.6	2 1/4 63.5	1 1/4 31.8		
2	7.6	1	2 3/8 60.3	1 1/8 28.6	2 54.0	1 1/8 28.6	2 1/4 63.5	1 1/4 31.8		
3	11	1							3 1/4 82.5	1 1/2 38.1
4	15	1							3 1/4 82.5	1 1/2 38.1
5	19	1							3 1/4 82.5	1 1/2 38.1
6	23	1							3 1/4 82.5	1 1/2 38.1
7	26	1							3 1/4 82.5	1 1/2 38.1
8	30	1							3 1/4 82.5	1 1/2 38.1
9 - 16	34 - 61	2							5 127.0	3 1/2 88.9
17 - 24	64 - 91	3							5 127.0	3 1/2 88.9
Series FC – Pipe Size			1"		1 1/4"		1 1/2"		2"	
Basic Part Number			FC100*		FC125*		FC150*		FC200*	
5	19	1	3 1/2 88.9	2 50.8						
6	23	1	3 1/2 88.9	2 50.8						
7	26	1	3 1/2 88.9	2 50.8						
8	30	1	3 1/2 88.9	2 50.8						
9 - 16	34 - 61	2	5 127.0	3 1/2 88.9	5 127.0	3 1/2 88.9				
17 - 24	64 - 91	3	5 127.0	3 1/2 88.9	5 127.0	3 1/2 88.9				
25 - 32	95 - 121	4			5 1/4 133.3	4 101.6	5 1/4 133.3	4 101.6		
33 - 40	125 - 151	5			5 1/4 133.3	4 101.6	5 1/4 133.3	4 101.6		
41 - 64	155 - 242	8					6 1/8 155.6	4 1/2 114.3	6 1/8 155.6	4 1/2 114.3
65 - 96	246 - 363	12							7 1/4 184.2	5 1/2 139.7
97 - 120	367 - 454	15							7 1/4 184.2	5 1/2 139.7
Series FC – Pipe Size			3"							
Basic Part Number			FC300							
65 - 96	246 - 363	12	7 1/4 184.2	5 1/2 139.7						
97 - 120	367 - 454	15	7 1/4 184.2	5 1/2 139.7						

Important: Flow above 9 GPM (34 LPM) up to 120 (454 LPM) specify exact flow rate (and not the flow range) desired, in increments of 1 GPM. E.G. to order a 1" PVC valve with EPDM seals and a desired flow of 12 GPM, the correct model number is FC100EP-12-PV-12-PV.

TEMPERATURE vs. PRESSURE									
Mat'l	Max. Temp. Rating	75°F PSI	24°C BARS	110°F PSI	43°C BARS	140°F PSI	60°C BARS	180°F PSI	82°C BARS
PVC	140°F (60°C)	120	8	90	6	30	2	N.R.	N.R.
PP	180°F (82°C)	120	8	90	6	60	4	30	2
PTFE	180°F (82°C)	120	8	120	8	90	6	90	6
PVDF	180°F (82°C)	120	8	120	8	90	6	90	6

NOTE: 3/4" to 3" sizes with flow rates from 9 GPM (34 LPM) up to 120 (454 LPM) are Specialty Custom orders; consult factory for availability. Minimums may apply.