

SERIES PRHM - PRESSURE REGULATORS INSTALLATION & MAINTENANCE INSTRUCTIONS

1. IMPORTANT – BEFORE INSTALLING

Series PRHM pressure regulators will prevent downstream pressure from exceeding the set pressure, when properly installed and used within the recommended ranges of pressure, temperature, and chemical compatibility. A Pressure Regulator *does not* maintain a specific downstream pressure if inlet pressure or flow is too low. The ultimate determination of material compatibility is previous successful use in the same application. See the Product Data Sheet or call our Technical Support for information about your application.

Caution: Quick closing valves installed downstream of the regulator may cause water hammer. This may cause leakage or seal damage. Plastic materials will degrade in ultraviolet (UV) light or sunlight. Polypropylene and PVDF (Kynar®) often look similar. Do not install in your system if you are not sure.

2. PRESSURE RATINGS

A. Maximum Inlet Pressures for Water*

Body Mat'l	Color	at		at Max. Temp.	
		77°F (25°C)	104°F (40°C)	PSI @ °F	Bar @ °C
PVC	Dk. Gray	150 PSI 10 Bar	106 PSI 7 Bar	34 @ 140°F	2 @ 60°C
CPVC	Lt. Gray	150 PSI 10 Bar	120 PSI 8 Bar	37 @ 180°F	2 @ 80°C
Polypro	Trans. Wht.	150 PSI 10 Bar	120 PSI 8 Bar	40 @ 180°F	2 @ 80°C
PVDF	Trans. Wht.	150 PSI 10 Bar	120 PSI 8 Bar	22 @ 280°F	1 @ 140°C
PTFE	Opaq. Wht.	150 PSI 10 Bar	140 PSI 10 Bar	Consult Factory	

* or compatible chemical – ratings reduced for some applications
Not rated for suction or vacuum. Min. Temperature 40°F (5°C).
EPDM seals limited to 250°F (120°C), Viton to 300°F (149°C).
See the Product Data Sheet or consult our Technical Support staff for more information.

B. Set Pressure Range: 5 - 125 PSI (0.3 to 8 Bar)

3. INSTALLATION

Install the valve in the proper flow direction as indicated by the flow label. The valve may be positioned vertically or horizontally. Proper installation should include pressure gauges mounted upstream and downstream of the regulator for pressure setting and verification.

Threaded Connections – Apply a suitable thread sealant (for example, PTFE Tape) to male tapered threads to assure a “leak-tight” seal. Assemble “hand-tight” followed by a quarter (1/4) turn with a strap wrench. Do not over tighten or use pipe wrenches on plastic pipe and components.

Caution: PTFE tape will “string” as pipe threads are joined. Loose “strings” could lie across the seating surface and prevent the valve from completely closing. To avoid this problem, clean out old tape, and do not apply tape to the first thread.

Caution: Connect to plastic pipe and fittings only; when using metal pipe, install an intervening plastic fitting. Metal pipe and straight threaded pipe tends to cut, stretch, and distort the plastic bodies, resulting in cracking or leaking over time.

Non-Threaded Connections – For solvent cementing or heat fusion, follow the instructions supplied with the cement or fusion equipment, or contact your distributor.

Mounting – These valves are designed to be supported by the piping. The piping must be properly supported, taking into account the weight of the valve, piping and process liquid.

4. PRESSURE SETTING

Series PRHM senses downstream pressure; a pressure gauge should be installed at the outlet of the valve to accurately set the regulator. Downstream set pressure range is 5 to 125 PSI. The following procedure is for static (no flow) pressure setting. Under flow conditions, the outlet pressure may be slightly lower.

1. Install the regulator in the piping system. Close all downstream outlets to stop flow. The inlet pressure must be higher than the desired set pressure.
2. Loosen the Lock Screw: Loosen the stainless steel lock screw on the upper side of the spring housing, one-half (1/2) to one (1) turn only. Requires a 5/32" allen key. It is important to loosen this lock screw not more than one turn.
Do not remove this lock screw – it will be difficult to reinstall.
3. Adjust the Pressure Setting Screw: Insert a 3/8" allen key in the top of the regulator spring housing to change set pressure. Adjust the set pressure only when the unit is pressurized. From the top of the regulator, looking down on it, turn clockwise to increase set pressure or counter clockwise to decrease set pressure.
4. Tighten the Lock Screw: When the desired pressure setting is achieved and the unit is under line pressure, re-tighten the lock screw with the 5/32" allen key to a torque of 10-15 inch-pounds (1.13 – 1.17 Newton-meters). Do not overtighten.

PRHM-0322-I-1

SERIES PRHM - PRESSURE REGULATORS INSTALLATION & MAINTENANCE INSTRUCTIONS

Pressure can also be set under dynamic (with flow) conditions using the same procedure. If pressure is set under dynamic conditions, outlet pressure will increase when downstream flow is reduced.

Note: Series PRHM Pressure Regulators are *non-relieving*. Outlet valves must be open to allow pressure to drop.

5. MAINTENANCE

Plast-O-Matic recommends keeping a spare seal kit available for repairs. Seal life will vary in applications due to cycles, temperatures, pressures, chemicals, and concentration. Based on the application, a periodic inspection and maintenance plan should be established. The seal kit part number is "SK" plus the part number less the material suffix. For example, the seal kit for PRHM200V-PV is SKPRHM200V.

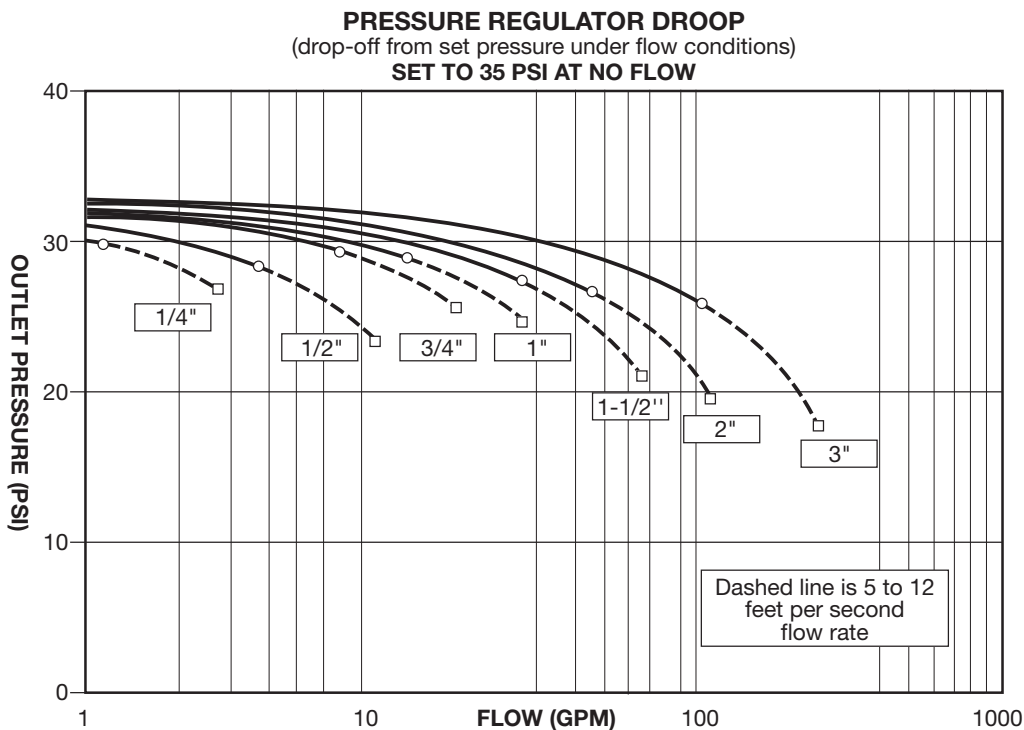

PRHM-0322-I-2

SERIES PRHM - PRESSURE REGULATORS PARTS & ASSEMBLY

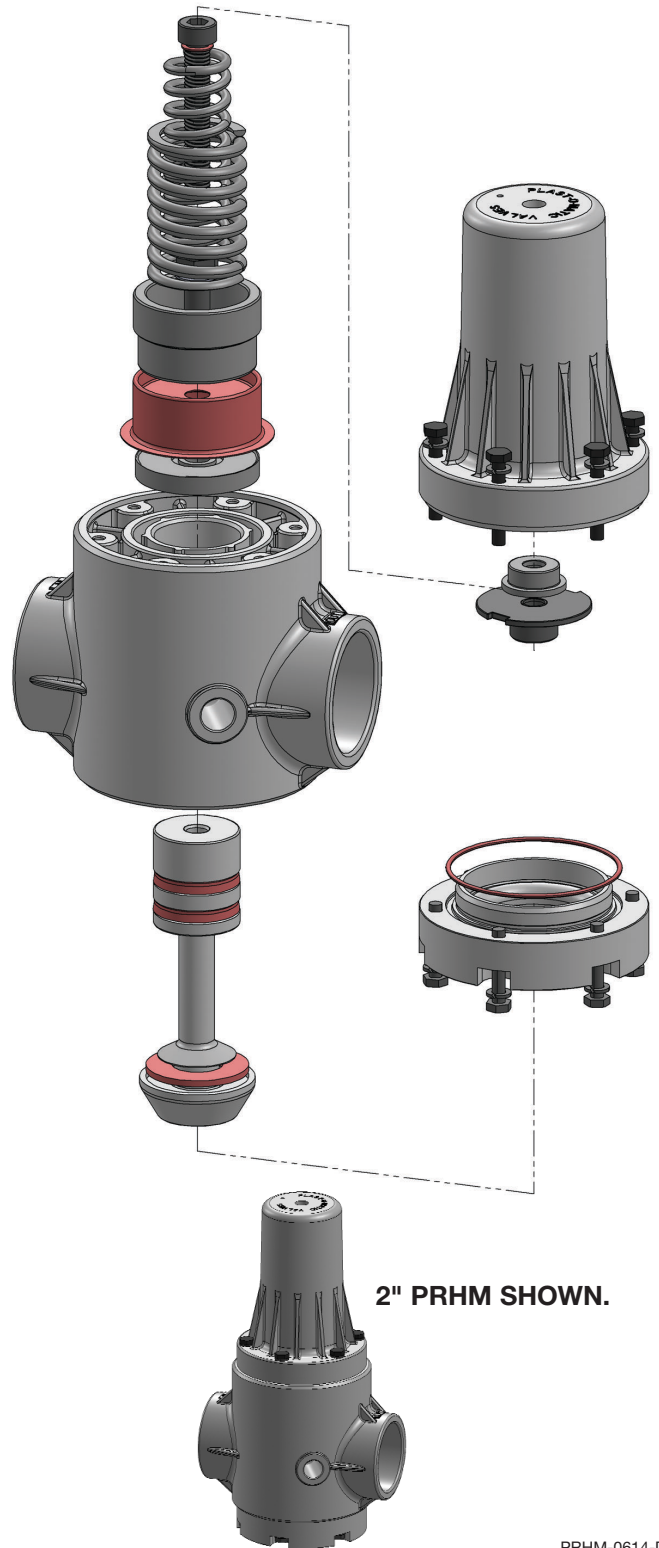
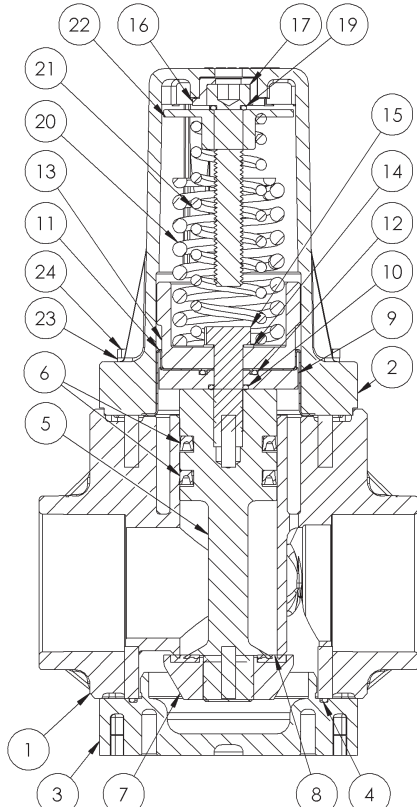

ITEM NO.	DESCRIPTION	QTY.
1	PRHM BODY	1
2	MACHINED SPRING HOUSING	1
3	MACHINED BASE PLATE	1
4	O-RING	1
5	SHAFT FOR PRHM	1
6	U-CUP	2
7	SEAT RETAINER	1
8	SEAT GASKET	1
9	DIAPHRAGM RETAINER	1
10	O-RING	1
11	ROLLING DIAPHRAGM	1
12	O-RING	1
13	PISTON	1
14	SS LOCKWASHER INTERNAL TOOTH	1
15	SS HEX HEAD TAP BOLT	1
16	ALUMINUM NRS BUSHING	1
17	LEFT HAND THREADS, NRS	1
18	SS S.H.C.S.	1
19	O-RING	1
20	MW SPRING FOR PRH	1
21	RIGHT HAND MW SPRING	1
22	NON RISING STEM	1
23	SS LOCKWASHER	12
24	SS TAP BOLT HEX	6
25	SS TAP BOLT HEX	6

PRHM-0614-D-1

FLOW CONTROL VALVES



Series FC
Internal snubber and orifice plate maintains constant, pre-set flow despite pressure fluctuations. Flow rate is tamper-proof and available from 1/4 GPM to 1 GPM. 1/4", 1/2", 3/4", 1"

PULSATION DAMPENER/ SUPPRESSOR



Series PDS
Performs six functions to improve system performance: Pulsation Dampener smooths pump flow, Surge Suppressor absorbs vibrations, Water Hammer

Arrestor, Inlet Stabilizer enhances pump operation, Accumulator releases stored fluid during unwanted pressure drops, Expansion Tank protects system from thermal volume increases. 10, 50 and 180 cubic inch capacity in 1", 2", 3" connection, respectively. PVC, CPVC, PP, PVDF

SOLENOID VALVES



Series EASYMT/EASMT
Normally-closed design/energize to open. Million-cycle design featuring PTFE bellows; direct acting. Available with choice of rectified coil or rectified 'Z-Cool' energy saving 24 watt coil. 120/60, 24/60, 240/60 AC or 24V DC 1/4", 1/2", 3/4", 1" sizes with 3/8"-1 1/4" main orifice

PVC, CPVC, GPP, PVDF



Series EAST
Compact, normally-closed design/energize to open. Million-cycle design featuring PTFE bellows; direct acting. Available with 11 watt, NEMA 4X coil.

120/60, 24/60, 240/60, 230/50 AC or 24V DC 1/4", 1/2" sizes with 3/8" or 1/4" main orifice
PVC, PP, PVDF



PS
Pilot-operated, normally-closed design/energize to open. Million-cycle high flow rate valve features PTFE bellows; require pressure differential to function. Available with 11 watt, NEMA 4X coil.

120/60, 24/60, 240/60, 230/50 AC or 24V DC 1/4", 1/2", 3/4", 1", 1 1/2", 2", 3"
PVC, CPVC, PP, PVDF

SHUTOFF VALVES



Series BSDA/BSDAM
Air operated, compact PTFE diaphragm valve for drain applications and pressures to 100 PSI. 1/4", 1/2", 3/4", 1", 1 1/2"
PVC, CPVC, PP, PVDF, PTFE



Series BSR
Air operated, balanced shaft design assures bubble tight shutoff with automatic spring return. 1/2", 3/4"
PVC, PP



Series MFR
Hand or foot operated manual valve. Press to open, automatic spring return closure. 1/2", 3/4"
PVC

GAUGE GUARDS & INSTRUMENTATION



Series GGS
Heavy duty instrument isolator; 1/2" process connection with steel reinforced 1/4" instrument connection. Available with or without pressure or vacuum gauges. Standard instrument has 2 1/2" gauge face with stainless steel case. Options include center back mount, acrylic shield for harsh environments, snubber, liquid filled face. PVC, CPVC, GPP, PP, PVDF



Series GGMU
Ultrapure, zero deadleg instrument isolator with spigot connections. Available with or without pressure gauge. Standard instrument has 2 1/2" gauge face with stainless steel case. Options include DI water fill and high purity clean/double bag procedure. PVC, PP, PVDF



Series PT
Combination 0-160 PSI pressure and 0-180°F temperature 'Tridicator' gauge. Brass connection with 2 1/2" gauge face or stainless steel connection with 3" gauge face.

INSTRUMENTATION



Series SWT
PTFE diaphragm pressure switch features no wetted metals or elastomers. 16, 25, or 3 Amp models. PVC, CPVC, PP, PVDF



Series CC
Calibration columns feature 100% UV-resistant PVC; remain clear and easy-to-read for years. Rapid fill rates and longer testing periods improve efficiency and accuracy. 100, 250, 500, 1000, 2000 and 4000 ML

SIGHT GLASSES & LEVEL INDICATORS



Series GX
Single-wall sight glass for liquids compatible with acrylic. Fluttering streamers optional. 1/2", 3/4", 1", 1 1/4", 1 1/2", 2", 3"
PVC, PP



Series GY
Double-wall sight glass for liquids compatible with Pyrex inner wall. Fluttering streamers optional. 1/2", 3/4", 1", 1 1/4", 1 1/2", 2", 3"
PVC, PP



Series GYW
Double-wall sight glass for liquids compatible with Pyrex inner wall. Flange connections; fluttering device optional. 1 1/2", 2", 3", 4", 6", 8"
PVC, CPVC, PP, PVDF, PTFE

OPTIONS & ACCESSORIES

- High Purity Cleaning Procedure
- Factory setting on pressure control valves
- High Purity Flare Fittings
- Flange Connections
- High Purity Spigots